



NIKOMI

LASER / BEND / WELD

Hello
and welcome.

Learn more about
our company





**Welcome in our
company profile**



Experts in mechanical engineering solutions

Innovation, precision and quality –
your guarantee of success in
mechanical engineering.

About us

We are experts in custom, serial and small-batch
production of mechanical engineering products
made from stainless steel and steel, as well
as in industrial constructions and mechanical
engineering services.

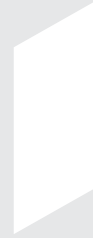

Index

ABOUT US 04.

VISION AND VALUES OF THE COMPANY 08.

EXPERTISE AND EXPERIENCE OF THE TEAM 10.

PRODUCTS AND SERVICES 12.

**TECHNOLOGICAL BACKGROUND
AND PRODUCTION CAPACITIES** 16.

PRODUCTION AREA 18.

QUALITY AND CERTIFICATIONS 20.

**SOCIAL RESPONSIBILITY
AND SUSTAINABILITY** 22.

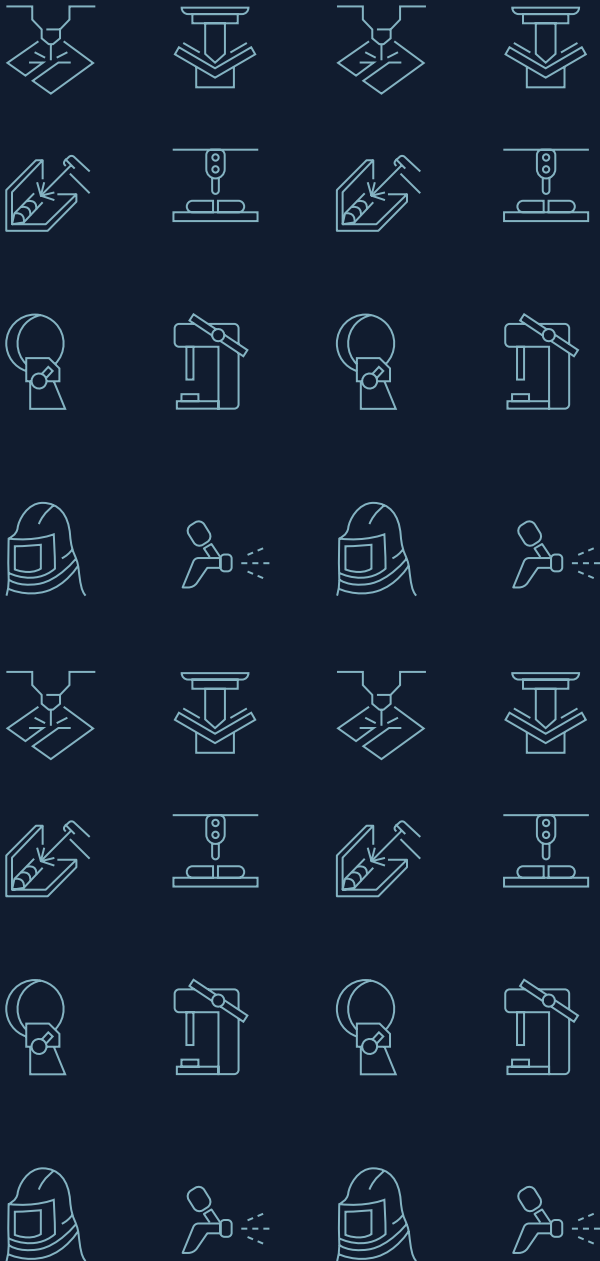



About us



First class products
and services



A reliable partnership
with suppliers



Strong support
for employees

NIKOMI continues to grow to the present day. By constantly improving processes and reflecting on new technological trends in the industry, we fulfil our ambition to hold a leading position on the market.

We guarantee

Overview of the development
of the company



2010 The early days of the company

The path to the large mechanical engineering company NIKOMI began modestly – with a small family business. Our production workplace had been resonating with metal sounds for a long time, but our story started out rather unconventionally.

2016 Expanding our portfolio

We expanded our portfolio with the sector of mechanical engineering production. We bought new machinery, and also our human resources were growing. This marked the beginnings of the NIKOMI company – the industrial branch of our business. At first, we specialised mainly in the production of catering equipment and smaller steel constructions.

By uniting the mechanical engineering brand NIKOMI with the joinery REZBA, we were able to combine and join talents and materials from both worlds in one company. This way we could, for example, equip a corner shop with durable stainless steel elements and embellish it with elegant wood cladding.

2017 Achieving company certification

With greater responsibility and a wider portfolio of services came higher demands for quality assurance.

At that time, the company NIKOMI obtained the certifications ISO 9001:2015, EN 1090-2+A1:2011, STN EN ISO 3834 PART 2.

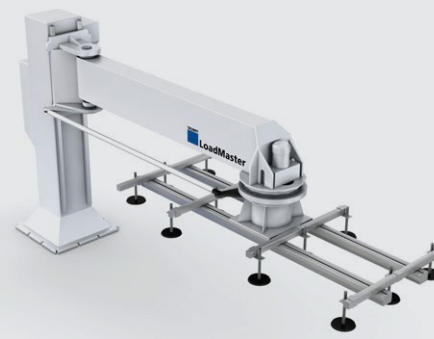

2019 Constructing a new production hall

We started to build a new hall, which, after completion, would further expand our production portfolio.

NIKOMI thus continued on its way to an important position within the mechanical engineering industry. The new hall had become necessary to streamline production processes and create new opportunities for the company's long-term growth.

2021 Expanding the production portfolio

The new hall meant we could put what we had envisioned into practice – we significantly expanded our production. We started to produce large steel constructions. In the new hall, we had twelve separate welding workstations and also a crane with a load capacity of up to 16.5 tonnes. Thanks to these production capacities along with our human capital, we managed to create a place for ourselves on the market of quality companies. We were able to transform steel and stainless steel into countless products and areas of use.

2022 Continuing our expansion

We put into operation new warehouse spaces and a new workplace for blasting – surface treatment of metals with micro-glass beads.

We also expanded the office space for our construction and technological support.

2023

purchase of a new **TruLaser 3040 fiber laser**, as well as the construction of a new hall for aforesaid, which enabled us to further separate the stainless steel production from the black steel processing.



SENSITIVE FAMILY CARPENTRY

www.rezba.sk

2019 | Generation change in a family business



Natalia Nikodem
Executive director

Branislav Nikodem
Executive director

Michaela Michalkova
Executive director

Igor Opet
Production manager

Miroslav Porubsky
Production foreman

We believe that we are one of the companies that successfully completed a generation change, where the younger generation took the lead, and the original one remained an important advisor. Thanks to this exchange, the company benefitted from innovative views on technological development and new approaches to the development of a family business. At the same time, a new production hall was constructed, which meant undeniable development and growth for our company and the possibility to offer an expanded portfolio of services to our customers. Nonetheless, we are aware that preserving our values and culture is crucial in building a company.

Therefore, our clear goal has been and will remain to maintain the already established trust and the status as a reliable partner to our customers.





Vision and values of the company

Get to know our company
visions and values





Strong support for employees

At the core of NIKOMI's values are **strong social relationships** between people and a working environment oriented towards employees and their satisfaction.



A reliable partner for suppliers

We also **maintain reliable business relations** with customers and suppliers; we favour **long-term business partnerships**.



Sustainability

We also respect **sustainable development** and the **environment**.



First class products and services

As a company, we have been in excellent shape for a long time and constantly invested in new technologies and education. This is why we provide products which out-perform the competition in quality.





A certified team with more than 10 years of experience

Expertise and experience of the team

→

The company's ability to offer first-class products and services is based on the long-term experience of our experts. Quality is ensured at management level, which itself has many years of experience in the field.

Our employees have **10 or more years of experience** in the field of engineering production. Welders are **certified**. Both the welders and the executive managers have professional experience in the field of mechanical engineering.

Gradually, we have built a team of experienced professionals with the determination and desire to engage in engineering production in our company.

Our human capital has been strengthened by additional experts, in the position of head of production, foreman (head of the production department) and an experienced quality manager.



Our personal capital grows every year along with the expansion of our production capacities.

Year and number of employees:

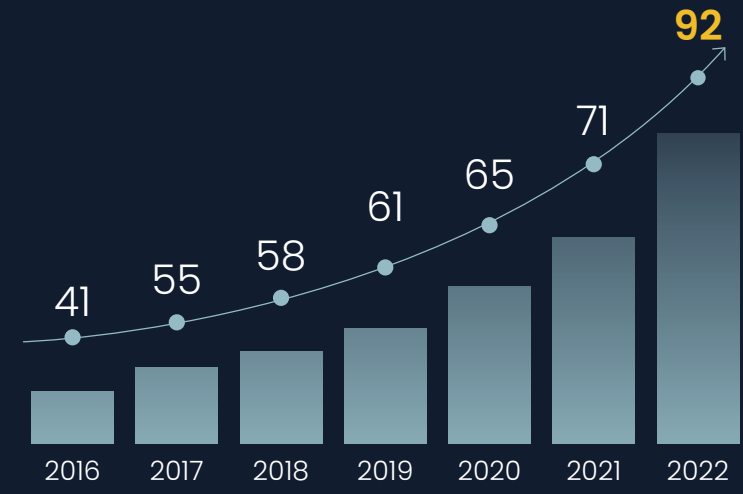

The average number of employees, self-employed people, and contractors together



**Products
and services**

Learn more about our
products and services



Products

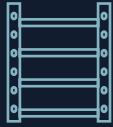

Welded constructions

We produce consistently processed metal products from small to multi-tonne:

- > Small weldments
- > Large weldments up to 16.5 tonnes



Conveyor systems

Important transport equipment for specialised industrial production.

- > Adaptability of dimensions and angles of conveyor belts
- > Flexibility of the transport route in the desired direction or elevation
- > Different types of conveyors: belt, roller and others



Vibrating conveyors

We manufacture vibrating conveyors according to the needs of our customers, with emphasis on the design's quality. Their diverse use allows the transport of various materials in the production and processing procedure.

Ideal for transporting:

- > Powders, grains, seeds, raw materials of food
- > Stones, metal parts, wood shavings or other small objects



Products



Structural elements, building structures

Quality and reliable construction products for various industrial purposes. Our offer includes production of platforms, industrial structures and production halls, railings, stairs, industrial chimneys and other building construction elements.



Catering furniture, catering equipment

Professional catering and restaurant establishments, that need to comply with strict hygiene standards, trust our long-term experience in the production of catering furniture and equipment.





Services



Technical documents

Trust our professional design department to create the technical documents. Our designers have professional experience in the production of stainless steel and steel structures.

- > Technical construction drawings
- > Production documents
- > Consulting for technical construction drawings



Consulting

You can rely on the know-how of experts: we provide professional assistance in choosing the right materials and technologies, and align your production with the latest innovations in the industry.



Installation of constructions

- > Installation of production machines, structures and production lines

During assembly, our technicians take into account the specific requirements of each installation, including the most suitable spatial layout and aesthetic criteria.



Logistics solutions

We offer flexible shipping options. We transport machines, constructions, or entire production lines to the desired location, even with overstandard dimensions.



Technological background and production capacities



Description of modern technologies and equipment

Our innovative technological facilities are very important to us. They allow us to achieve efficient and high-quality results.

Thanks to our machinery and high-quality human potential, our company is able to offer the production of large weldments.

The biggest size possible:

Height: 3 m

Length: 14 m

Width: 2,5 m

Weight: 16,5 t

We also produce small components which are used in the production of machines in the electrical industry. We process and prepare these products for electropolishing, which requires very precise work by our specialised grinders.

We provide elementary components for the food industry, construction industry, electrical industry, pharma industry and also in the recycling industry.

In production, we use the CITO ERP system and are gradually implementing digitalisation elements.

We produce and process stainless steel separately from black steel:

- TruLaser 3040 fiber laser for burning and cutting stainless steel sheets and TRUMPF LC 4030 laser for black steel.
- 2 sets of press brake tools, 1 set for stainless steel products only, 1 set for black steel only.

We have two separate production areas: a hall with a 16.5t crane for stainless steel material and another hall with a 3.5t crane for processing black steel.

Machinery

- TRUMPF LC 4030 / 2015
- a new fiber laser TruLaser 3040 – acquired in October 2023 – with max. size of processed materials up to 2000x4000 mm and max. thickness up to 25 mm
- AMADA 4m/220t – press brake metal sheet bending machine – 3-cylinder, width: 2000mm, thickness of circled sheet: 4mm
- metal sheet bending machine – 4-cylinder, width: 2000mm, thickness of circled sheet: 6mm
- mechanical metalworking cutter FNK 25 A with electronic measurement
- lathe SV 18 with electronic measuring
- band saw Pegas
- band saw Pilana used only for black material
- welding machines LORCH 14 units – welding using the TIG, MIG, MAG/-CO2 methods, power from 180–400
- gantry crane 2x – load capacity up to 16.5 t and up to 3.5 t
- surface treatment of metals – sandblasting, blasting with micro-glass beads, cabin size: 5 x 12 x 5 m
- deburring machine Etagrind
- deburring machine lissmac
- forklift, 2x, 2,5 t
- new manual sanding cabin with suction
- belt sanding machine + accessories GRIT GI 1502H



**Production
capacity available**

**Find out more about
our premises**



Our production facilities have been expanding over the years.

Here we present an overview of the spatial capacities of our production:

- When we bought the land in 2015, our premises had an area of **590 m²**.
- Black steel welding shop + sheds (grinding shop, dispatch) in 2016:**1315 m²**.
- New hall / welding shop, in 2020:**489 m²**.
- Bulk material warehouse in 2021:**460 m²**.
- Hall for sanding / blasting in 2022:**222 m²**.
- Offices in 2022: **92 m²**.
- Small tools and goods warehouse in 2022: **50 m²**.
- New laser hall in 2023:**270 m²**.

Graphical representation

Activities in units of production hours:

Burning/cutting: 12480 hours

Welding: 41600 hours

Blasting: 6240 hours

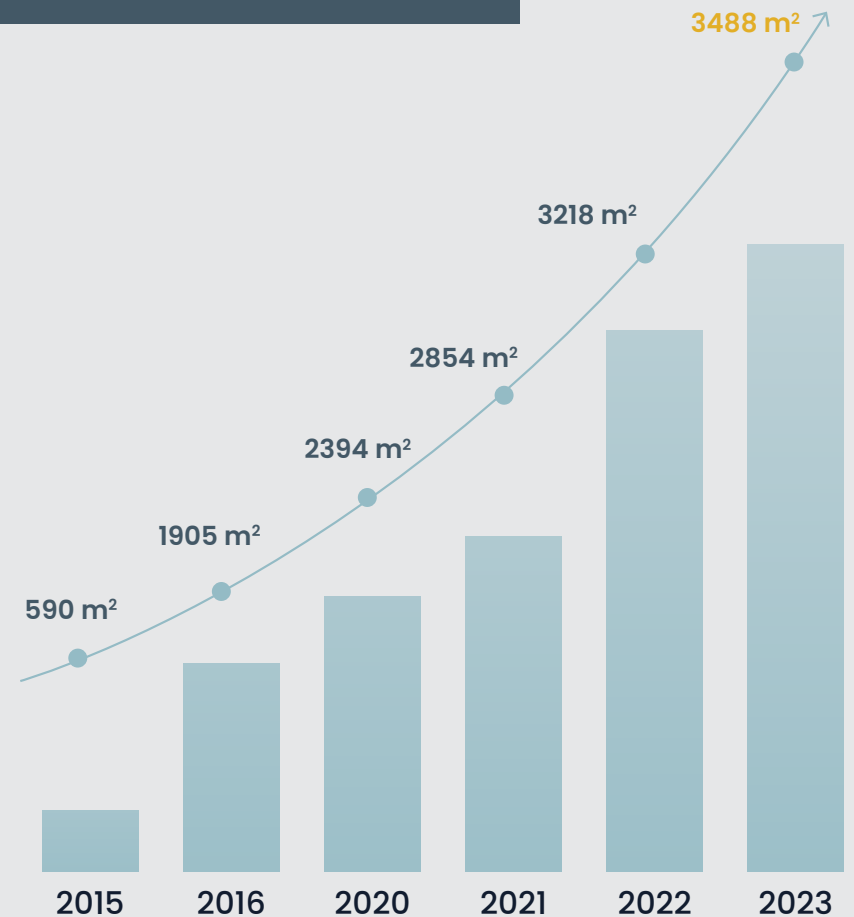



QUALITY COMMITMENT and QUALITY MANAGEMENT SYSTEM

We hold the **ISO 9001:2015**, **EN 1090-2+A1:2011**, **STN EN ISO 3834 PART 2** certifications. In Dec. 2022, we received the **ECOVADIS** certificate with a silver medal award.

These certifications prove our dedication to top products, quality services and efficient processes.

Quality and certifications

Certificates





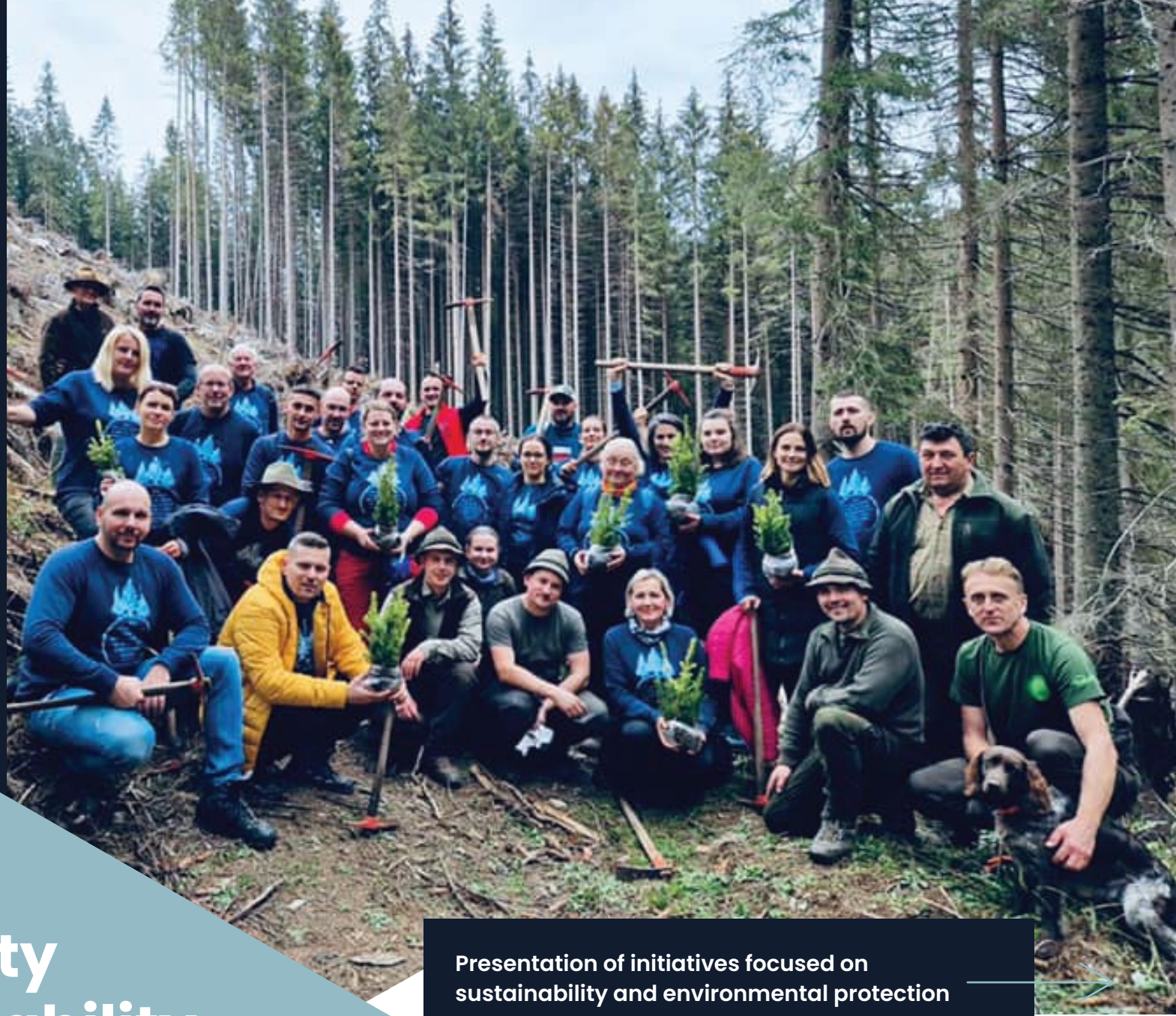

Social responsibility and sustainability

Presentation of initiatives focused on
sustainability and environmental protection

We plant new trees

In October 2022, we participated in the nationwide event „A million trees for Slovakia.“ Together with the foresters from Čierný Váh, we planted 2 000 seedlings. By these means, we also cultivate the surroundings of our premises.



Sustainable energy

Since 2023, we actively use energy from ecological photovoltaic devices.

Work clothes and ecology

We rent work clothes and use ecological detergents to wash them.

We light sparingly

In December 2022, we replaced all lamps with ecological ones, equipped with photocells.

Public services

We proactively fulfill goals for the benefit of the public and local communities.

At the entrance to the premises, we have placed an **AED Defibrillator**, which is available 24 hours a day to the public.

We work closely with the municipality and the local primary school and support them in their activities.

We sponsor the folklore group Tancovadlo and the sport club Triatlon Team Trnava.





NIKOMI

LASER / BEND / WELD

**You can find more
information about our
company on our website.**

www.nikomi.sk

Do not hesitate to contact us,
should you have any questions

